



LIPI MARKETING PVT. LTD.

Follow Us at



KENJET

1.8m Hybrid UV Machine

KG - UH 1800 (Ricoh Gen5 / Gen6)

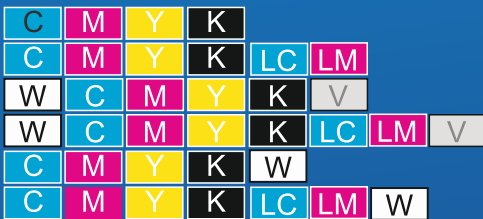
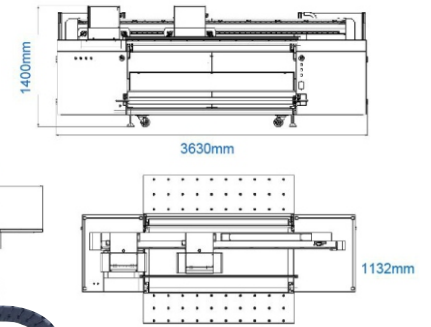

**2400
dpi**

Max Resolution



Variable Drop



Simple Operation



Continuous printing

C/M/Y/K/Lc/Lm/W/Varnish

Technical Characteristics

- ▶ Standard Extension Platform, Perfect Competent to Print both Roll and Rigid media.
- ▶ Cold light LED Curing with Tiny Temperature Variation Ensures High Printing Quality.
- ▶ Adjustable Head Height, Laser Positioning System and Movable Printing Platform Result in High-Efficiency Printing Jobs.
- ▶ Air-shaft Take up System makes more Stable Paper Collecting
- ▶ Stable Printing Technology and ink Supply System Reduces Maintenance cost.
- ▶ International ICC Standard with Profile Curve Adjustment Function.

Specification



Integrated Belt & Flatbed Media Feeding System is Competent to print both roll and rigid media. Folding extension Frame saves and cost well. Independent widened platform is able to accommodate more materials Air-Shaft take up system makes more stable paper collecting

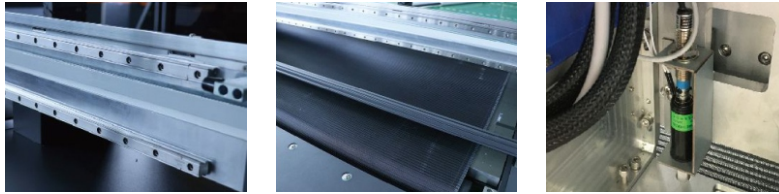

Dual mute THK Guide rails Ensure Stability of Printing and High Quality Printing output The Sheet Media is Automatically Positioned, and the assistance of the front pressure bar makes the material more smooth, ensuring the accuracy of printing. Automatic Height measurement system, adjust the distance between the base plate and the media automatically to guarantee the best quality



Front LED Lamp enhances the accuracy of color and makes the printing output more real. Multi functional Vacuum Platform is divided into six areas to Control accordingly with adjustable Vacuum power the material is always in good status during the printing process to avoid wrinkling Bulky ink with Ink alarm system represents the advanced concept of industrial application to ensure Long -term stable printing

Technical Parameter

Print Head Type	Ricoh Gen5 / Gen6
Number of Head	3 - 9 Optional
Printing Size (W x D)	1800(X) x 1000mm(Y)
Printing Technology	Gray Scale Piezoelectric Inkjet Technology
Maximum Resolution	Up to - 2400Dpi
Ink Type	LED UV INK
	Continual Ink Supply System (2.5L Ink Tank)
	C/M/Y/K/Lc/Lm/W/Varnish
Media Thickness	≤50mm
Colour Control	ICC Standard, Adjustment of ICC and Density
RIP	Photoprint
Environment	Temperature: 18°C - 26°C; Humidity: 30-75% (RH)
Power consumption	Printing Mode:5000W ; Sleep Mode: 600W
Printer Dimension (L x W x H)	3630 x 1132 x 1400mm
Packing Dimension (L x W x H)	3750 x 1300 x 1800mm
Packing Weight	1.4T



LPI MARKETING PVT. LTD

No: 28, 3rd Cross St, Venkateswara Colony, OMR Nehru Nagar, Kottivakkam, Chennai - 600041

+9194443 95467 / +91 94443 95477 ✉ sales@lipimarketing.com 🌐 www.lipimarketing.com